

Technical News Bulletin

April 11, 2007

FlexIS Line-server

1. Introduction



The FlexIS Line-server from Emhart Glass supports the user of FlexIS control systems in Offline Job Creating, Automated Periodic Data Backup and Production Reporting. The handling of the Line server is comfortable and easy to learn, as it features the same structure and look-and-feel as the FlexIS User Console.

The FlexIS Line-server can only be used with the Emhart Glass FlexIS-Technology

The software tools operate on Microsoft operating system.

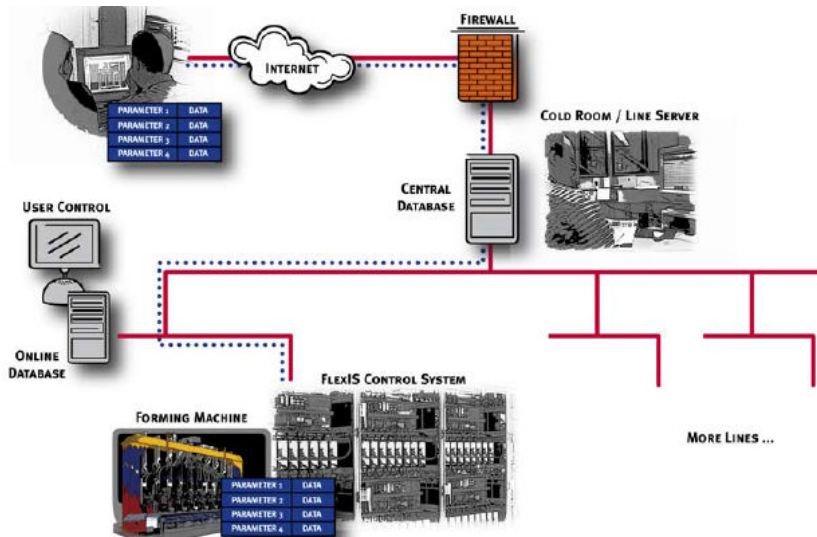

This concept with the single-integrated networking technology for the entire Forming-machine allows:

- Transparent communication and access to any device with Ethernet-connection which is installed within the FlexIS Control System
- Remote access for support and troubleshooting.

The software tool supports the user with following features:

- Offline access
- Jobhandling
- Statistics
- Production Data access / interface
- Backup and Restore procedure
- Read-only access to a running job

2. Network-structure

As the Network Emhart Glass uses for the Line server is Standard Ethernet TCP/IP technology and the Emhart Glass Forming-machines use the same technology. The operator has a full and transparent overview of the whole FlexIS Control System. Standard interfaces and gateways are used.

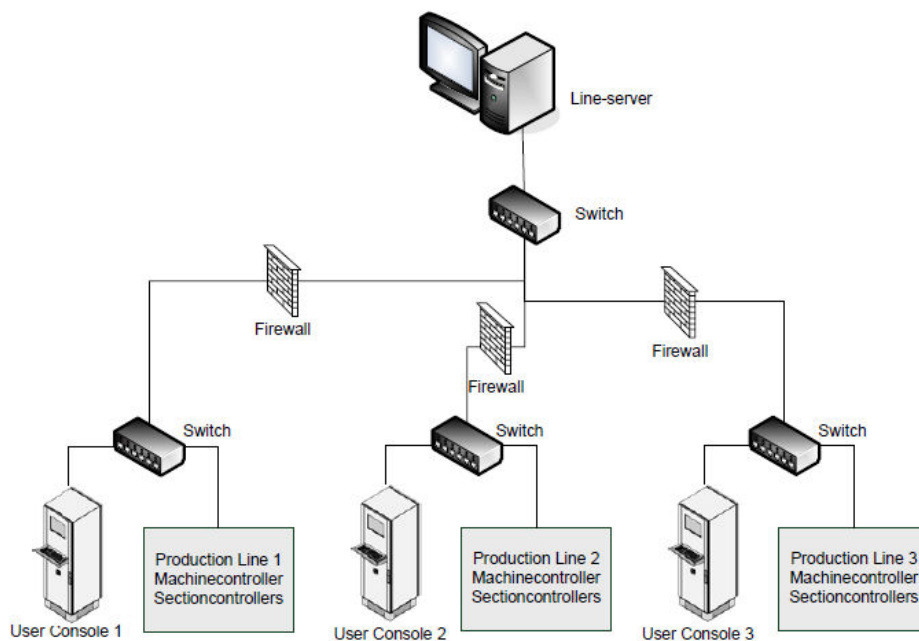

Up to 16 Production Lines can be supervised with one Line-server.

3. Lineserver Software features

3.1 Data viewing / editing:

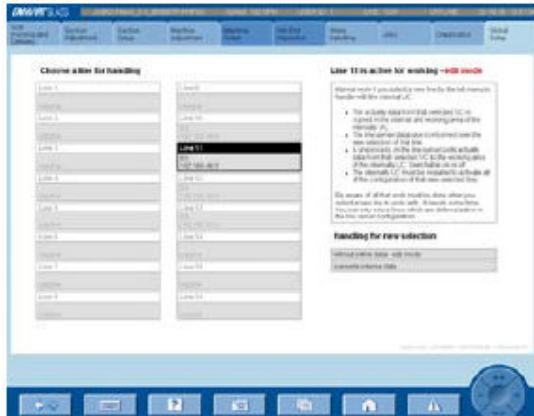

It's easy for the operator access any of User Consoles. Once accessed data can be view only, or view and edit (except for running jobs). In the Viewing-mode all data is continually updated from the respective User-Console.

3.2 Job-Handling

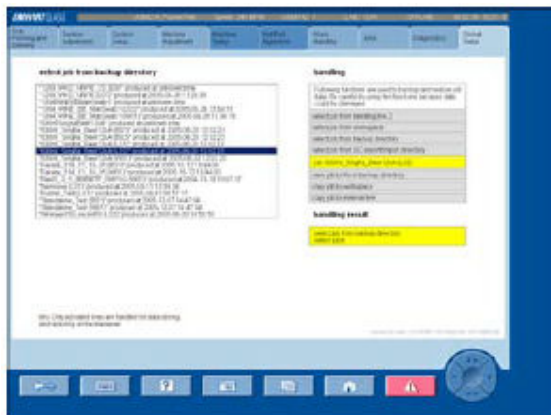

For the operator it provides following features:

- Select and upload a job from a Selected Line,
- workspace or backup-directory
- Save job into a backup directory
- Copy job to the workspace or an external line

3.3 Export Production Data

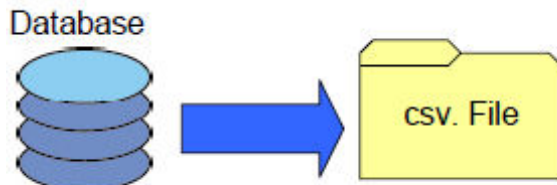

As it becomes more important to supervise the production, the Line Server permits the exporting of data for Production Reporting. This is available as csv files, allowing the customer to develop his own production reports. Examples of data that can be exported include:

- Number of cut gobs
- Number of gobs delivered
- HEWR 1 – HEWR 4

3.4 Backup procedure

The Line-server backup automatically executes, every 24 hours. It can also be manually initiated. The Line-server saves the whole database from the connected User-Consoles. The database includes all Job-relevant data, Alarms, Production data.

The old database will override automatically. If required the user can provide a backup on a DVD.

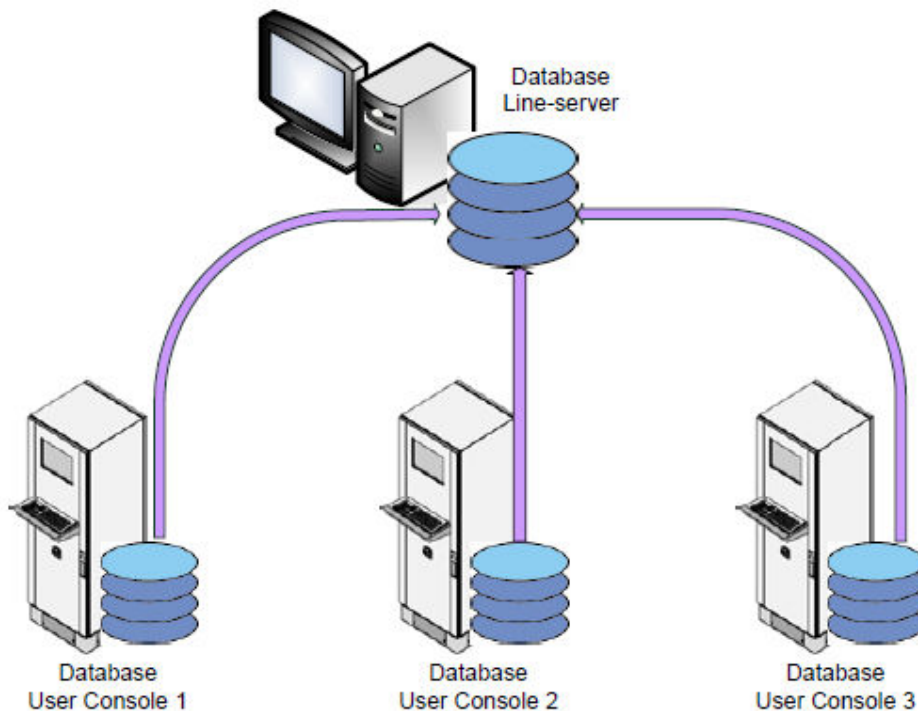

The Line-server is able to manage data up to 16 User Console Databases.

4. Hardware

The Line-server Hardware includes following components:

- Server with UPS (Uninterruptible Power Supply)
- RAID system
- DVD Reader / Burner
- 19" Monitor
- Cisco Layer-3 – Switch